

EdgeCard Switch™ User Manual



Green Edge Computing Corp.



This document is the property of Green Edge Computing Corp. and may not be copied nor communicated to a third party without the written permission of Green Edge Computing Corp.

Revision History

Date	Revision Description	Revision
2025/10/01	First release.	A.1
2026/03/04	Added compliance information	A.2

Table of Contents

1	Related documents	4
2	Product summary and key features	4
2.1	What you will find in the box	4
2.2	Installation instructions.....	4
2.3	Requirements for power, network, and cooling	4
2.4	Specifications	4
2.4.1	Technical Specifications.....	4
2.4.2	Network OS Specification.....	5
2.4.3	Regulatory Compliance	7
2.4.4	Errata	7
3	Front Panel Description	8
3.1	Power LED	8
3.2	Reset Button.....	8
3.3	Console Interface.....	8
4	Switch Management via CLI	8
4.1	Driver Installation	8
4.2	CLI Access	9
4.3	CLI Basics	9
5	Switch Management via WebUI	10
5.1	WebUI Access	10
5.2	WebUI Basics	11
5.2.1	Firmware Update.....	12
5.2.2	Saving changes.....	12
6	Port Map	13
7	Warranty	14

1 Related documents

- EdgeCard Switch Datasheet
- TN001 (EdgeCard Removal and Installation)
- UM002 (EdgePod User Manual)
- QF001 (GECCO Warranty)

2 Product summary and key features

The EdgeCard Switch is designed for easy installation in the secure, low power EdgePod Edge Computing Appliances.

The EdgeCard Switch provides reliable high-speed connectivity between all installed EdgeCard Servers, with two 10Gbps copper or fiber uplink connections to external networks.

2.1 What you will find in the box

- EdgeCard Switch
- Micro-USB Cable
- Reference Sheet & Compliance Information

2.2 Installation instructions

EdgePod installation: Insert the EdgeCard Switch into the switch slot in any GECCO EdgePod. The switch slot has two guide rails that provide support and heat transfer for the EdgeCard. The rear VPX connector provides connectivity for power and networking. Refer to TN001 (EdgeCard Removal and Installation) for detailed installation instructions.



The EdgeCard Switch is intended for installation in a GECCO EdgePod system. Operation outside of a certified host system may require additional regulatory evaluation or certification.

2.3 Requirements for power, network, and cooling

Power: The rear VPX connector provides power through the backplane of the GECCO EdgePod. Refer to section 2.4.1 for power characteristics.

Network: The rear VPX connector provides 10G Ethernet connections to the EdgeCard Servers through the backplane of the GECCO EdgePod. In addition, there are two 10G uplinks with control capability for copper or fiber SFP+ modules and one or more 1G copper Ethernet ports. Availability of ports depends on EdgePod configuration.

Cooling: When the EdgeCard Switch is installed in a GECCO EdgePod, the EdgePod provides the mechanism for drawing heat from the EdgeCard and disperses it from the outer shell of the EdgePod.

2.4 Specifications

2.4.1 Technical Specifications

Size	171mm x 100mm x 26mm (6.7in x 3.9in x 1.0in)
Weight	0.63 kg (1.38 lbs)
Power	10W nominal

Cooling	Passive (no internal fan)
Operating Temperature	0 to 55 °C (32 to 131°F)
Connectivity – front	Micro-USB Console Port
Connectivity – rear	Model GVX1-P1: - 2x 10G SFI - 6x 10GBASE-KR - 1x 1000BASE-T
Power supply	12VDC via backplane
Predicted operating life	10 years
Management	CLI over Console Port Web-based User Interface

2.4.2 Network OS Specification

Time Sensitive Networking (TSN)	Description
Shaping & Filter	IEEE 802.1Qbv-2015 - Time Aware Shaping IEEE 802.1Qbu/802.3br - Frame Pre-emption IEEE 802.1Qav AVB - Traffic shaping IEEE 802.1Qci-2017 - per Stream Filtering and Policing
Redundancy / reliability	Redundancy with IEEE 802.1CB Frame Replication and Elimination for Reliability (FRER) Protection switching (line or ring)
Forwarding Scheme	Cut-through option per TSN Stream and Store and Forward
Timing & Synchronization	IEEE 802.1AS-2020 1-step and 2-step IEEE 1588v2 1-step and 2-step for ordinary, boundary and transparent clocks
Network Redundancy	Description
Spanning Tree Protocol	IEEE 802.1D/1w/1S, STP/RSTP/MSTP
Port Trunk / LACP	Static trunk or LACP (Link Aggregation Control Protocol) G.8032, MRP IEC-62439-2 2016
Bridge, VLAN, Protocols	Description
Switching	IPv4/IPv6 unicast and multicast L2 switching
Routing	IPv4/IPv6 unicast and multicast L3 forwarding with RPF RFC 2992 (ECMP) with static routing RFC 2453 RIPv2 Dynamic routing RFC 2328 OSPFv2 Dynamic routing RFC 2740/5340 OSPFv3 Dynamic Routing
Flow Control	IEEE 802.3x (full duplex) and back-pressure (half duplex)

Max. VLANs	4095
VLAN Types	Port-based VLAN, IEEE 802.1Q tag-based VLAN
Multicast Protocols	IGMPv1, IGMPv2, IGMPv3, MLDv1, MLDv2 up to 255 multicast groups IGMP snooping, querying
Network Discovery	IEEE 802.1ab LLDP
Traffic Management & QoS	Description
Priority	IEEE 802.1p QoS
No. of queues per port	8
Scheduling schemes	Strict Priority Queuing (SPQ) Deficit-Weighted Round Robin Queuing (DWRR)
Security	Description
Port Security	IP and MAC-based Access Control/Filter, Auth. User / Privilege Level Control, IEEE 802.1X
Storm Control	Multicast / Broadcast / Flooding Storm Control / Port Access Control / Limiters
Management	Description
User Management	Web-based management, Command Line Interface (CLI)
Interfaces	SNMP v1/v2c, Trap, Telnet (5 sessions) RFC 3411 SNMP Management Frameworks RFC 3414 User-based Security Model for SNMPv3 RFC 3415 View-based access Control Model for SNMP RFC 2613 SMON - PortCopy
Management Security	HTTPs, SSH, Access Management, Loop Protection
Upgrade & restore	TFTP/HTTP for configuration import / export TFTP/HTTP for firmware upgrade
Diagnostic	Syslog, Level Info / Warning / Error Port Mirror (one group), Per VLAN mirroring, CPU Load Monitor Traffic Counter ICMP Ping
DHCP	Client Mode, Server Mode, Relay Mode, Snooping
Network Time	NTP Client
System Status	Device info/status; Ethernet port status

2.4.3 Regulatory Compliance

Product Classification

The EdgeCard Switch is an Ethernet switch module intended for integration into a GECCO EdgePod system. It is not a standalone finished product.

When operated outside of a GECCO EdgePod enclosure, the EdgeCard Switch is intended for engineering evaluation, development, or system integration purposes and may require additional regulatory compliance testing depending on the final application.

System integrators are responsible for ensuring that the final product complies with all applicable regulatory requirements when the EdgeCard Switch is operated in a system other than a GECCO EdgePod.

System-Level Compliance

The EdgeCard Switch does not carry independent FCC, ISED, or CE certification. Regulatory compliance is evaluated at the system level when the EdgeCard Switch is installed in a GECCO EdgePod enclosure and operated as part of a complete GECCO EdgePod system.

When installed in a GECCO EdgePod system, the platform is designed to meet applicable regulatory requirements including:

- IEC 62368-1:2023 safety requirements (evaluated with applicable U.S. and Canadian national differences for CSA/UL 62368-1)
- FCC Part 15 and ISED ICES-003 electromagnetic emission limits
- Applicable European Union directives, including the Radio Equipment Directive (RED 2014/53/EU) and RoHS Directive (2011/65/EU)

Regulatory Documentation

For the EU Declaration of Conformity and full regulatory compliance statements, refer to the EdgePod T41 User Manual (UM002).

2.4.4 Errata

The following table shows known issues with the EdgeCard Switch:

Issue #1	EdgePod power up and reboot of an EdgeCard Server may result in a non-working Ethernet link between the EdgeCard Switch and the EdgeCard Server.
	<p>Behavior is seen with switch software image 3.01 and earlier and may occur powering up the EdgePod or rebooting the Operating System on an EdgeCard Server. The link is reported as “up” but no Ethernet traffic is possible. The work around to re-enable Ethernet traffic is to reset the EdgeCard Switch in one of the following three ways:</p> <ol style="list-style-type: none"> 1. Using the reset button on the front 2. Using the CLI interface command “reload cold” 3. Using the WebUI (Maintenance->Restart Device->Yes) <p>Please contact GECCO for update on this issue and availability of switch software updates.</p>

3 Front Panel Description

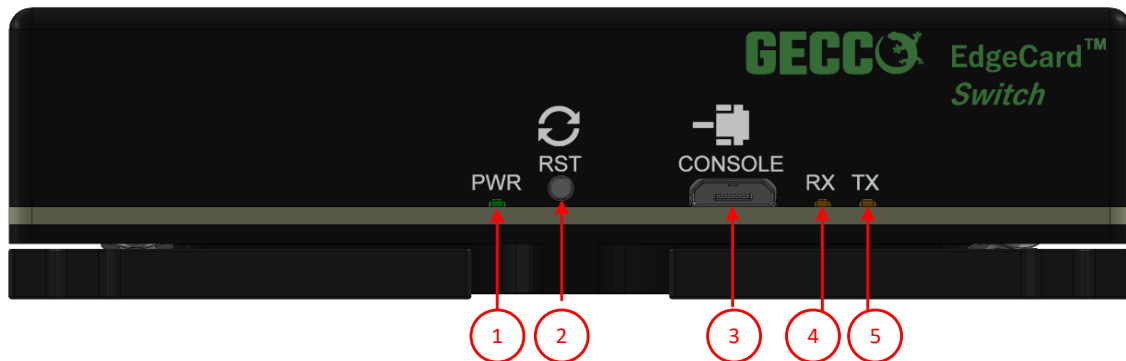

- 1 Power Indicator LED (green)
- 2 Reset Button
- 3 Console Interface (Micro-USB)
- 4 Console Receive Indicator LED (orange)
- 5 Console Transmit Indicator LED (orange)

3.1 Power LED

The green power LED is always on when the EdgeCard Switch is powered.

3.2 Reset Button

The reset button can be used to force a reset. The EdgeCard Switch has a miniaturized reset button that avoids accidental operation for maximum uptime of the switch. Only a quick press is required to reset the switch, which means the button can be released immediately after activation. A small click will be noticeable when the button is activated.

3.3 Console Interface

The console interface consists of a Micro-USB connector for serial port access and two orange LEDs to indicate when data is received (RX) or transmitted (TX) over the serial port. The console interface provides Command Line Interface (CLI) access. For further information about the use of the CLI management interface, refer to section 4.

4 Switch Management via CLI

The EdgeCard Switch provides Command Line Interface (CLI) management access via the front panel console port. A standard Micro-USB cable is required to connect to the console port.

4.1 Driver Installation

The console port uses a Silicon Labs CP210x USB to UART Bridge. Before being able to access the switch through the console port, drivers may need to be installed on the user's computer. Download and install the VCP Drivers from the Silicon Labs website:

<https://www.silabs.com/software-and-tools/usb-to-uart-bridge-vcp-drivers>

4.2 CLI Access

This section uses Tera Term as the terminal application. This is an example, and other terminal applications, such as RealTerm, Putty, HyperTerminal, minicom, etc. may be used. The terminal application needs to be configured with the following serial port parameters:

- Baud Rate: 115200
- Data bits: 8 bit
- Parity: none
- Stop bits: 1 bit
- Flow Control: none

When the switch is started up, ENTER is required to progress to the login prompt. At the login prompt use the default username: **admin**. No default password is set, so leave blank and press ENTER.

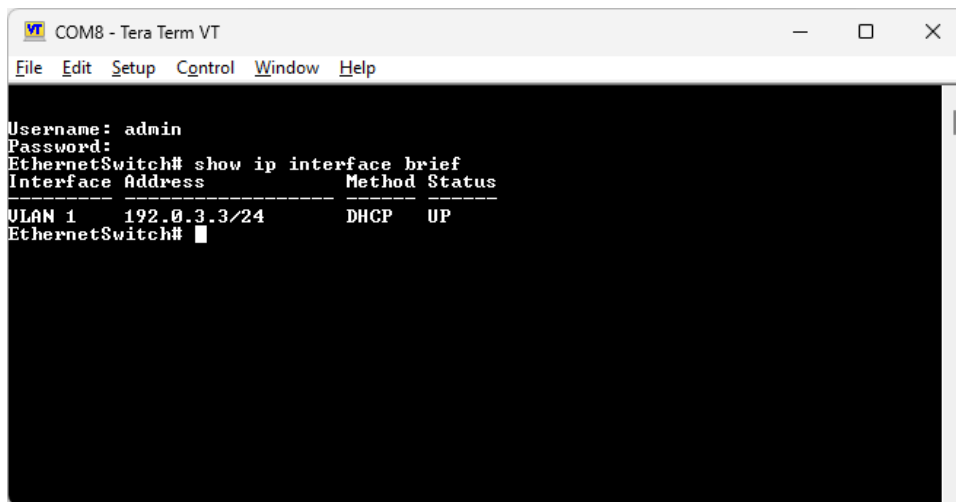

```
COM8 - Tera Term VT
File Edit Setup Control Window Help
Username: admin
Password:
EthernetSwitch# show ip interface brief
Interface Address Method Status
-----
VLAN 1 192.0.3.3/24 DHCP UP
EthernetSwitch#
```

Figure 1. EdgeCard Switch Console Login

4.3 CLI Basics

The CLI contains a context-sensitive help feature. Use the `<?>` symbol to display the next possible parameters or commands and their descriptions. Below is a list of common quick CLI commands.

Common Task	CLI Command Syntax
Show the IP address used by the switch:	<code>show ip int br</code>
Show what ports are linked and at what speed:	<code>show int * status</code>
Show the software version of the switch:	<code>show ver</code>
Setup static IP for VLAN1:	<code>conf t</code> <code>int vlan 1</code> <code>ip add xxx.xxx.xxx.xxx 255.255.255.0</code> <code>end</code>
Reset the switch to last saved configuration:	<code>reload cold</code>
Reset the switch to factory default configuration:	<code>reload defaults</code>
Save the current configuration for next startup:	<code>copy running-config startup-config</code>

Most changes made through the CLI will take effect immediately. To undo any changes and return to the previously saved configuration, run the CLI command “reload cold” or use the push-button on the front panel. To revert to factory default settings, use the CLI command “reload defaults”.

Changes made through the CLI will be lost by a power cycle or reset of the switch, unless saved. To make sure the configuration is retained, run the CLI command “copy running-config startup-config”.

5 Switch Management via WebUI

The EdgeCard Switch allows users to configure and monitor the switch from any web enabled device. Below describes how to access this web-based management interface.

5.1 WebUI Access

There are two ways to access the web interface for first time use.

Method #1 - Using the assigned or default IP address

This method does not require having access to the CLI. By default, the EdgeCard Switch is expected to receive an IP address from an external DHCP server (for example a gateway, router, or dedicated DHCP server on the network). If no IP address is assigned to the EdgeCard switch within the timeout of 30 seconds, the EdgeCard Switch will fallback to a default IP address of 10.10.10.1. To connect to this IP address, follow the steps below:

- Directly connect an uplink port of the EdgePod to your host PC using a standard Cat5e Ethernet cable.
- Setup your host PC's IP address to be on the same subnet as the EdgeCard Switch. For example, using a static IP address 10.10.10.2 and subnet mask

255.255.255.0. The process to do this depends on operating system and is beyond the scope of this document.

- Open a web browser and go to <http://10.10.10.1>. Note that HTTPS is disabled in factory default settings.
- The login screen should appear and from here the EdgeCard Switch can be set to an IP address on the final network.

Method #2 – Changing the EdgeCard Switch IP to one on the final network via the CLI

This method requires having access to the CLI through the console port:

- Login to the CLI
- Type in the following commands
 - configure terminal
 - interface vlan 1
 - ip address xxx.xxx.xxx.xxx 255.255.255.0
 - end
- Now connect EdgeCard Switch to any place on the final network.
- Once the system is up, go to the specified address of “http://xxx.xxx.xxx.xxx” in a web browser the login screen for the web interface should appear. Note that HTTPS is disabled in factory default settings.

To login into the web management interface, the default login is **admin** and the password is blank. (See below).

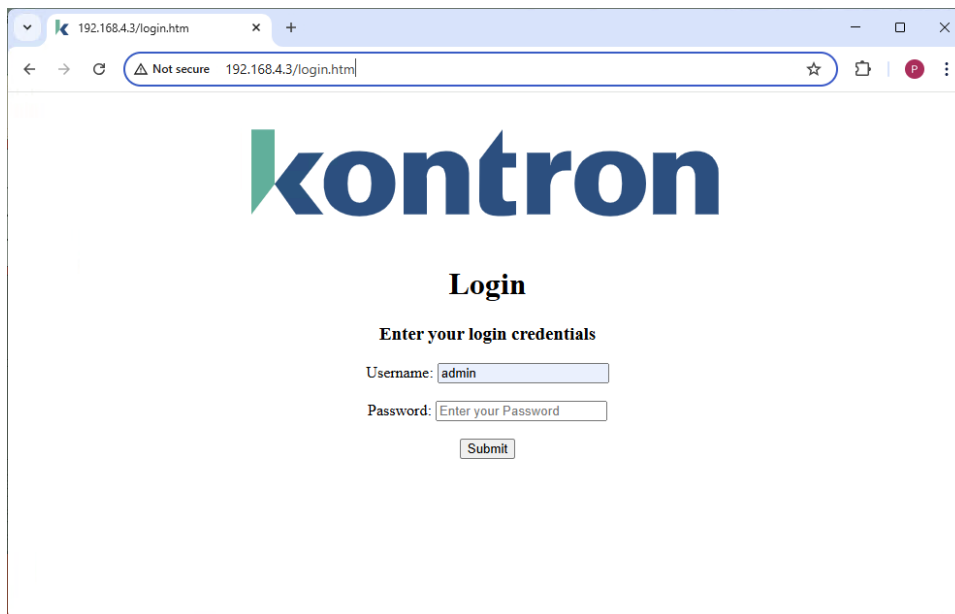

Figure 2. WebUI login page

5.2 WebUI Basics

The WebUI supports a comprehensive help menu providing information about functions and corresponding configuration options. Navigate to any menu on the left hand side, then click the question mark in the upper right corner to access additional information.

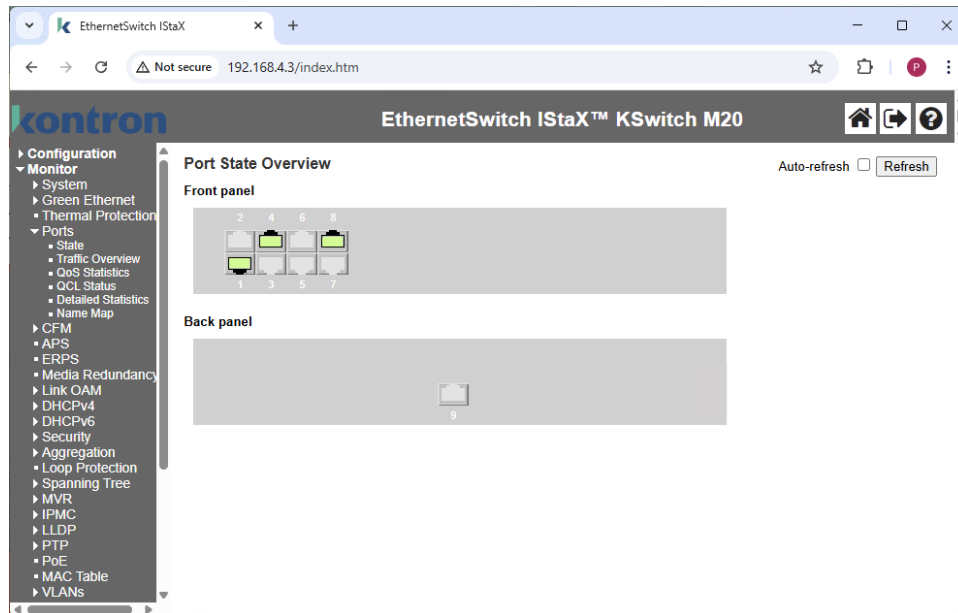

Figure 3. WebUI home screen

5.2.1 Firmware Update

To update the firmware, perform the following:

1. Access the WebUI and note the current firmware version.
Monitor → System → Information
2. Obtain an official firmware update file from GECCO.
3. Execute the firmware update.
Maintenance → Software → Upload
4. After installing the new firmware, the switch reboots.
5. Check that the new firmware is stored as 'Active Image' and the previous firmware is stored as 'Alternate Image'.

5.2.2 Saving changes

Most changes made in the WebUI will take effect immediately. There is a possibility that certain changes cause the WebUI management interface to be inaccessible. If this happens, the recommendation is to reset the switch to return to the previous configuration. This can be done through the push-button on the front panel or the CLI.

Changes made through the WebUI will be lost by a power cycle or reset of the switch, unless saved. To make sure the configuration is retained, click "Save Configuration" in the "Maintenance → Configuration → Save startup-config" menu.

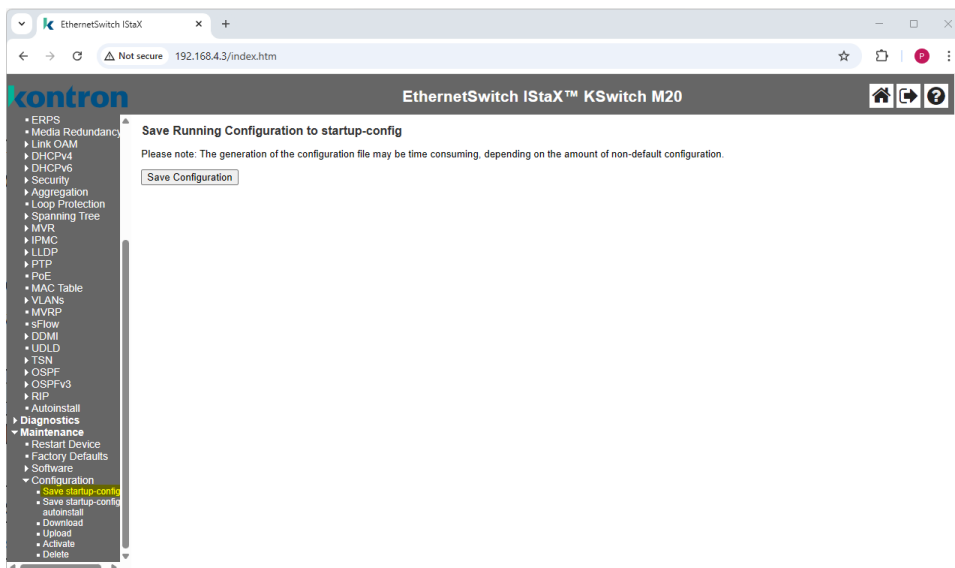

Figure 4. Save start up configuration through the WebUI.

6 Port Map

Port availability and speed varies depending on EdgePod generation and EdgeCard Switch ordering code. This section specifies available combinations.

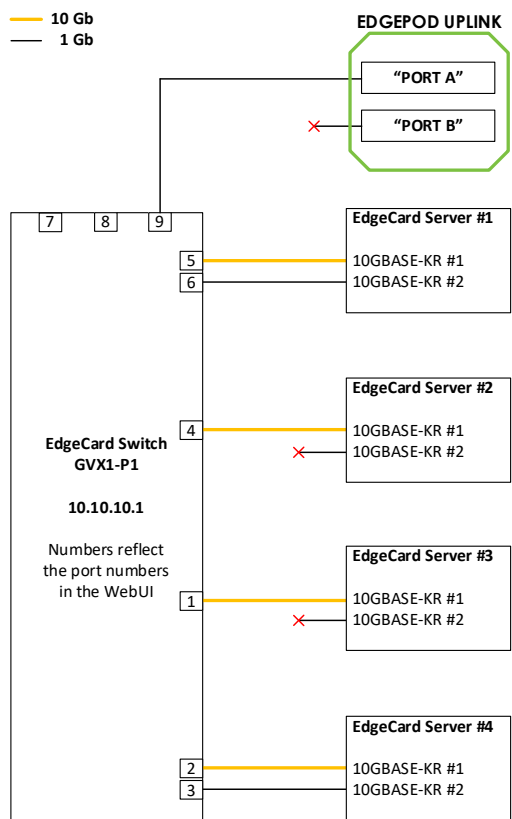

Figure 5. GVX1-P1 in EdgePod T41 (V4)

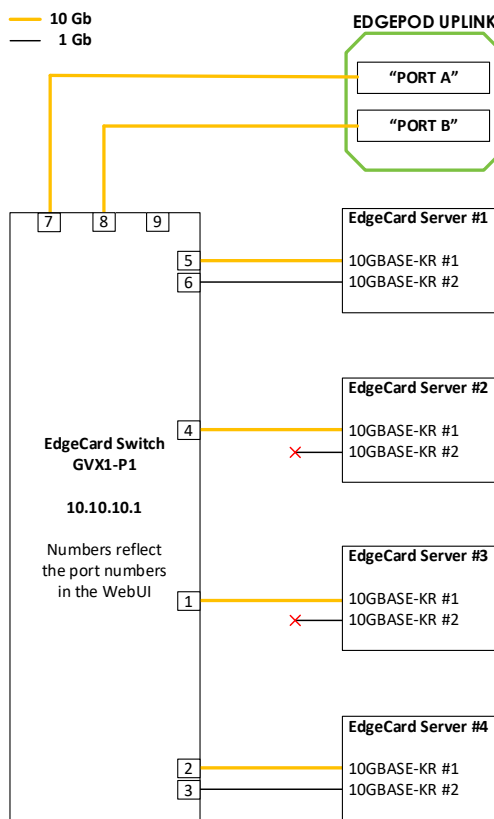

Figure 6. GVX1-P1 in EdgePod T41 (V5)

Table 1. Port Map GVX1-P1

WebUI Port Nr.	CLI Name	Interface	Max. BandWidth	EdgePod T41 (V4) Mapping	EdgePod T41 (V5) Mapping
1	10GEthernet 1/1	10GBASE-KR	10 Gb	Server 3 – I/F 1	Server 3 – I/F 1
2	10GEthernet 1/2	10GBASE-KR	10 Gb	Server 4 – I/F 1	Server 4 – I/F 1
3	10GEthernet 1/3	10GBASE-KR	1 Gb	Server 4 – I/F 2	Server 4 – I/F 2
4	10GEthernet 1/4	10GBASE-KR	10 Gb	Server 2 – I/F 1	Server 2 – I/F 1
5	10GEthernet 1/5	10GBASE-KR	10 Gb	Server 1 – I/F 1	Server 1 – I/F 1
6	10GEthernet 1/6	10GBASE-KR	1 Gb	Server 1 – I/F 2	Server 1 – I/F 2
7	10GEthernet 1/7	SFI	10 Gb	Not connected	Uplink Port A
8	10GEthernet 1/8	SFI	10 Gb	Not connected	Uplink Port B
9	GigabitEthernet 1/9	1000BASE-T	1 Gb	Uplink Port A	Not connected
			Total: 63Gb		

7 Warranty

GECCO products carry a limited warranty. Please refer to the GECCO Warranty Policy [QF001] and your contracted terms and conditions of sale.