

Ultra-Compact Data Center with High Processing Capacity for Smart Grid Applications in Distribution Substations

Manuel Romero Castellanos
Comisión Federal de Electricidad
Redes Inteligentes
Cuernavaca, Morelos
manuel.romeroc@cfе.mx

Joel Guevara Aranda
Alianza Energética del Bajío
Ciudad de México, México
jguevara@alianzaenergetica.com.
mx

Madleen Laclef
Alianza Energética del Bajío
Ciudad de México, México
mlaclef@alianzaenergetica.com.
mx

Rudi Carolsfeld
Green Edge Computing Corp
Vancouver, Canada
rudi@g3cco.com

Abstract — The growing demand for increasingly advanced computational processing capabilities continues to grow in electrical power substations for smart grid applications, where interoperability with the largest volumes of data (big data) from sensors, cameras, relays protection, power quality meters, RTUs and other systems, require inference tools for rapid decision-making, automation and process control to provide an electrical energy service with quality, continuity and reliability. A compact, high-throughput nano-scale data center for substations has been developed, able to support all software applications and a wide range of operating systems, and take advantage of the numerous virtualization, containerization and cybersecurity tools that have been developed for large data centers and cloud computing systems. This miniaturized computing solution presents an ideal architecture for smart grid implementation in electric power substations where size, weight, power, cooling and security are critical considerations. This paper introduces the “Edge Cloud Appliance” as a new category of compact computing for deployment in electrical substations, offering a viable alternative to legacy vendor-specific computing systems.

Keywords — Compact data center, high processing capacity, Edge Cloud Appliance, rugged computing, industrial server, private cloud computing, cloud computing, virtual machine, virtualization, containerization, container.

I. INTRODUCTION

As increasingly complex data sources are deployed at electric power substations, the demand for higher bandwidth networks connected to centralized data centers is also trending higher, leading to greater information capacity on the edge, that is, outside the traditional data center.

Conventional data collected and transferred via remote terminal units (RTUs) such as commands, status and alarms are only a small fraction of the total volume of data that substations currently generate, using high-definition cameras, for example, to identify stress thermal, perimeter security, damage to infrastructure, etc.

Intelligent electronic devices with high processing capacity are often deployed throughout the electrical grid for grid operations: automating substations and distribution circuits, as well as asset management and manual operation. This requires a compact data center with high processing capacity directly installed in electrical substations that can integrate all the information from various communication architectures and vendors, which comprise the Technology domain of a smart electrical grid. Such compact data centers offer an excellent solution for distribution substations, providing hardware with interoperable software applications and operating systems.

As smart grids continue to be deployed, and new concepts are introduced including artificial intelligence (AI), machine learning (ML), augmented and virtual reality (AR/VR), digital twins and cybersecurity algorithms, the volume of data will inevitably increase even more. The need to make quick decisions (inferences) based on these advanced algorithms will also increase in the coming years, and the latency of many network connections would make it impossible to centralize these decision-making processes.

Conventional RTU data typically represents a few tens of megabytes (MB) per month, transferred over network connections that rarely exceed 100 Mbps. In contrast, substations equipped with data from modern and future smartgrid systems can easily generate many terabytes (TB) per month and could quickly saturate network connections and overwhelm data transmission budgets.

Deploying a compact edge computing data center at the substation is an alternative to sending all substation data over public or private networks to centralized data centers. It also enables low latency decision making, which will become the new normal.



Fig. 1. Common in data centers, 19-inch racks and cabinets require dedicated space and are not ideal for substation use¹



Fig. 2. Compact edge computing appliance reference design in a 30cm cube chassis

II. IMPORTANCE OF SIZE, WEIGHT, POWER AND COOLING FOR SUBSTATION EQUIPMENT

Conventional server-type computing systems in data centers are typically installed in 19-inch racks and typically require dedicated power and cooling infrastructure. Although still popular after its introduction more than 100 years ago in 1922, the 19-inch rack does nothing to minimize space, and many data center designs are deployed more than half empty in anticipation of increased demand over time, as shown [1] in Figure 1.

Substations often do not have air-conditioned space that is suitable for such conventional data center systems, and may not have the 2000W to 5000W (or more) that might be needed for each rack of IT equipment. The need for a cold air handling system to keep this equipment cool can be an insurmountable obstacle in some situations.

This drives the need for a new category of Edge Cloud Appliances that are lightweight, wall-mounted, compact and rugged, provide controlled access to a cluster of miniaturized servers, and can operate without dedicated power and cooling infrastructure.

The compact Edge Cloud Appliance must also provide substantial data storage capacity to address the tsunamis of data that is likely to be generated in a modern substation, as well as integrated network interfaces with cybersecurity capabilities.

An example of such an Edge Cloud Appliance is shown in Figure 2, with four compute modules, a network switch module, and a data storage array in a rugged, fanless, secure, wall-mounted enclosure that minimizes size, weight, power consumption and cooling.

III. ADOPTING THE VPX STANDARD FOR SUBSTATIONS

Standardized interfaces ensure that systems and components from multiple vendors offer interoperability, and

this also applies to the standardized form factor and connectivity included in an edge computing appliance.

The VMEbus International Trade Association (VITA) developed the VITA65 VPX standard to address the challenges of high-performance computing when limited by size, weight, power consumption, and cooling. The VPX standard defines how modules are connected through a backplane with standard system topologies, or profiles [2], providing neutral architectural guidelines for designers and integrators.

Although VPX originally guided the design of robust computing modules for the defense and aerospace industries, VPX easily addresses the need for a computing hardware architecture that can meet the challenges of electrical substations and other deployments that require smaller size, lower power consumption, no dedicated cooling, better security, more robustness, modularity and upgradeability.

The Edge Cloud Appliance is a new category of products that are taking this technology from its origins in demanding military or space applications to a variety of civilian use cases, making them particularly suitable for use in electrical substations.

IV. VIRTUALIZATION IN SUBSTATIONS

Measurement, automation, protection and control systems are widely deployed in substations, and many of these systems rely on dedicated legacy computers for associated software. Dissolved gas analysis for transformers, thermography, security cameras and a host of other systems are introduced regularly, each requiring its own IT solution.

This can lead to many separate computing platforms that can be difficult to manage, especially when deploying new, more complex software solutions across hundreds, or even thousands, of substations in a distribution network.



Fig. 3. Miniaturized server-class computing module measures 100mm x 160mm

Virtualization allows software provided by a number of independent vendors to share the computing resources of a group of servers. Virtualizing these systems on a shared Edge Cloud Appliance can greatly simplify maintenance and repairs, and make it easier to manage spare parts and upgrades.

Although virtual machines (VMs) and containers, as well as the hypervisor software used to manage them, are now common in private on-premises data centers and public cloud data centers, these solutions have evolved rapidly and can now offer many advantages for a resilient and predictable data processing environment in substations that have been equipped with Edge Cloud Appliances.

V. VIRTUALIZATION WITH EDGE CLOUD APPLIANCES

Like any conventional rack-mounted server, each computing module installed in an Edge Cloud Appliance could simply be configured as a conventional server with a single operating system. There are substantial benefits, however, to deploying a small cluster of two or three servers in a substation and provisioning virtual machines (VMs) and/or containers as needed. Some advantages [3] are:

- Lower physical costs of resources
- Faster setup
- Ability to create backups
- Greater flexibility

Each VM or container instance could be capable of replacing a rack-mounted server or dedicated computer that would otherwise be required to run a systems provider's dedicated software solution, bringing measurement, automation, control, protection, dissolved gas analysis and other software to a common computing platform, each running in VMs or containers as needed.

Using a hypervisor, these VMs and containers can be managed centrally: they can be created or deleted, additional memory can be allocated when necessary, and software-defined network interfaces can be reassigned as needed. Software within each VM or container can be updated, or

replaced through automation that ensures consistent operating systems across many hundreds or thousands of substations.

VI. ADVANTAGES OF EDGE CLOUD APPLIANCES

In addition to the low latency advantages of local data processing, there may be other technical, operational, economic or security reasons for processing large volumes of data that will likely be generated within the substation as new software is implemented in the coming years.

From a data processor perspective, there is no significant difference between VMs running on a server cluster processing data from a database located on a substation, and VMs running on a server cluster processing data from a centralized database in a data center.

Edge computing data centers and the VMs and containers running on their servers can address the need for local, uninterrupted, real-time data processing in harsh environments that are subject to space constraints, have limited power infrastructure, and cooling, may have low or intermittent network bandwidth and require low latency response times.

If the Edge Cloud Appliance and servers adhere to the standard VPX profile, then the servers are completely interchangeable, greatly reducing cost, support effort, and logistical complexity.

The miniaturized VPX-aligned server shown [4] in Figure 3 is only 100mm x 160mm in size and weighs less than 750g. This is approximately 90% smaller and lighter than a comparable rack-mounted server, making it much easier to obtain spare parts, ship to site, store on site, remove and install. The connectorized design allows technicians with very little training to perform physical upgrades and replacements.

Wiring errors and connector failures that can be caused by user error or accidental contact represent a leading cause of system failure. Network integration into the rugged VPX backplane offers a connectorized solution that eliminates this risk. Low power consumption (typically less than 100W) and passive conductive cooling (no fans) reduce the likelihood of component failure and extend system life.

The current state of the art for these miniaturized VPX-aligned servers features Intel Xeon or AMD Epyc processors, with multi-core CPUs. Graphics streaming (g-stream) analysis via complementary GPU/AI accelerators may be supported. Onboard memory up to 64 GB (DDR4) and storage memory up to 16 TB (NVMe) per server are commercially available.

Long-term archival data storage is common in cloud data centers, and this concept can easily be extended to a widely distributed network storage facility. The ability to share storage between multiple servers requires easily replaceable solid-state storage modules (64 TB or more) within the compact Edge Computing data center. Interfacing with monitoring and control systems is common and readily compatible.

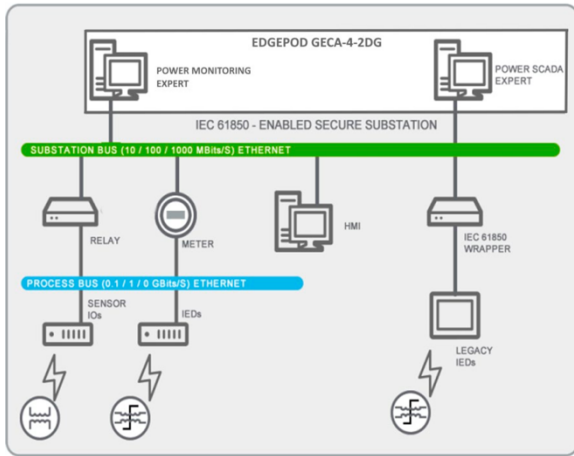

Fig. 4. Software reference architecture for electric power substation

VII. REFERENCE SOFTWARE ARCHITECTURE FOR SUBSTATIONS

The reference software architecture for a typical distribution substation is illustrated in Figure 4. Protective relays, meters, a variety of remote terminal units (RTUs) and other intermediate systems can be deployed at the substation and connected to the Edge Cloud Appliance.

The purpose of the software is to digitize the electrical substation, offering decision support to ensure smooth operations. Improve security, reliability, compliance and efficiency, ultimately driving operational improvements.

The software integrates with protection relays, meters, UTRs and other devices using various protocols such as DNP3, IEC 61850 and proprietary protocols. Establishing a fast and reliable connection with these devices is crucial to prevent data loss and provide real-time information to operators. Deploying the software at the substation level, hosted by the Edge Cloud Appliance, provides an ideal configuration for optimal performance.

Managing a considerable volume of data is essential, whether it involves providing real-time data and representing the substation single-line (shown [5] in Figure 5), or storing alarms, events, historical data and waveform captures.

To meet this demand, computing capacity at the substation level is necessary. This can be facilitated by the Edge Cloud Appliance, which hosts virtual machines (VMs) that contain the operating environments for each native software application designed for the substation equipment. These devices allow for future scalability of the system, accommodating the growing volume of data that must be managed.



Fig. 5. Substation one-line status diagram provided in real time by monitoring and control software

VIII. CONCLUSIONS

The implementation of smart electrical grids requires high communication and processing speed of all smart electronic devices in the electrical grid. The compact “Edge Cloud Appliance” data center with VPX standard offers a solid architecture for the design of a new category suitable for deployments in electrical distribution substations.

Lower power consumption and passive cooling allow Edge Cloud Appliances to be the perfect solution, overcoming the lack of dedicated air-conditioned computer room facilities.

Most existing substations have not been able to take advantage of significant advances in virtualization, containerization and asset management to achieve automation of substations and distribution circuits through hypervisor solutions that have been developed for cloud computing and private cloud installations.

By integrating compact Edge Cloud Appliances with high processing capacity and space for information (big data) within the substations, based on the design principles of the VPX standards, it is now possible to deploy compact, highly capable, multi-server systems that meet the requirements of substation environments, for the benefit of end customers and the profitability of the electric company.

REFERENCES

- [1]. <http://green-data.blogspot.com/2019/08/how-to-choose-data-center-racks-cabinets.html>
- [2]. ANSI/VITA 65.1-2021, OpenVPX™ System Standard – Profile Tables; October 4, 2021
- [3]. <https://www.dnsstuff.com/benefits-of-server-virtualization>
- [4]. <https://www.g3cco.com>
- [5]. <https://www.se.com/mx/es/product-range/65405-ecostruxure-power-operation#overview>

SOBRE LOS AUTORES

Manuel Romero has a Master's degree in Electrical Power Systems and Developer Leadership, and has more than 26 years of service in the Federal Electricity Commission. He is a leader in the implementation of smart electrical networks in Mexico. He is a specialist and consultant in compliance with the Grid Code and the Wholesale Electricity Market. Manuel has been a distinguished member and international speaker of the IEEE, CIGRE on topics of energy efficiency, renewable energy, grid automation, power quality and smart grids. He has represented the CFE in hurricane response in the United States, Puerto Rico and Cuba.

Joel Guevara Aranda is an Electrical Mechanical Engineer, UNAM, with more than 20 years of service experience in the field of Electrical Monitoring and control with ION technology. Joel has collaborated in these years in both monitoring systems for private industries and systems for government, and is CFE certified as an IEEE CPQ, Network Code consultant. He has to his credit the design of demand control algorithms and data visualization for the MEM.

Madleen Laclef received her degree in Electrical Engineering from the National Polytechnic Institute of Grenoble in France. With more than 17 years of experience in the energy solutions industry, Madleen has held various roles at Schneider Electric, including product management, marketing and business development. Throughout her career, Madleen has provided extensive support to clients globally, helping them implement world-class energy management solutions.

Rudi Carolsfeld received his Master of Electrical and Computer Engineering degree from University of Victoria in Victoria BC. He has over 25 years of experience with measuring systems, industrial controls & networking. Rudi has held senior executive roles in product management (including a co-invention patent), marketing and sales from early growth through acquisition of two significant Canadian technology companies: Power Measurement (Schneider Electric) and RuggedCom (Siemens). As co-founder and Chief Revenue Officer of Green Edge Computing Corp, Rudi strives to bring game-changing technology to clients that need more capable edge computing with a smaller operating cost and environmental footprint. Rudi has been a member of the IEEE since 1983.